

**INSTALLATION MANUAL**

# **AlpicAir air conditioner**

**CEILING AND FLOOR TYPE**

*For correct installation, read this manual before starting installation.  
This manual may be subject to change without notice for purpose of improvement.*

## INSTALLATION PRECAUTION

- To install properly, please read this manual at first.
- The air conditioner must be installed by qualified persons.
- When installing the indoor unit or its tubing, please follow this manual as strictly as possible.
- When all the installation work is finished, please turn on the power only after a thorough check.
- No further announcement if there is any change of this manual caused by product improvement.

**Note:** The installer should illustrate to users how to correctly use and maintain the air-conditioner, as well as remind users to carefully read and keep both Installation Manual and Owner's Manual well.

## INSTALLATION PLACE

### ■ The Indoor Unit

- There is enough room for installation and maintenance.
- The ceiling is horizontal, and its structure can endure the weight of the indoor unit.
- The air outlet and the air inlet are not impeded, and the influence of external air is the least.
- The air flow can reach throughout the room.
- The connecting pipe and drainpipe could be extracted out easily.
- There is no direct radiation from heaters

### ■ The Outdoor Unit

- There is enough room for installation and maintenance.
- The air outlet and the air inlet are not impeded, and can not be reached by strong wind.
- The place is dry and ventilative.
- The support is flat and horizontal and can stand the weight of the outdoor unit. And no additional noise or vibration.
- Your neighborhood will not feel uncomfortable with the noise or expelled air.
- There is no leakage of combustible gas.
- It is easy to install the connecting pipe or cables.

### Cautions

**Location in the following places may cause malfunction of the machine. (If unavoidable, please consult your local dealer.)**

- a. There exists petrolatum.
- b. There is salty air surrounding(near the coast).
- c. There is caustic gas(the sulfide, for example) existing in the air (near a hot spring).
- d. The Volt vibrates violently(in the factories).

- e. In buses or cabinets.
- f. In kitchen where it is full of oil gas.
- g. There is strong electromagnetic wave existing.
- h. There are inflammable materials or gas.
- i. There is acid or alkaline liquid evaporating.
- j. Other special conditions.

### ■ Notes Before Installation

1. Select the correct carry-in path.
2. Move this unit as originally packaged as possible.
3. If the air conditioner is installed on a metal part of the building, it must be electrically insulated according to the relevant standards to electrical appliances.



### **NOTE:**

Remark per EMC Directive 89/336/EEC

For to prevent flicker impressions during the start of the compressor (technical process), following installation conditions apply.

1. The power connection for the air conditioner has to be done at the main power distribution. The distribution has to be of a low impedance, normally the required impedance reaches at a 32A fusing point.
2. No other equipment has to be connected with this power line.
3. For detailed installation acceptance, please refer to your contract with the power supplier if restrictions do apply for products like washing machines, air conditioners or electrical ovens.
4. For power details of the air conditioner, refer to the rating plate of the product.
5. For any question contact your local dealer.

# ACCESSORIES

Name of Accessories	Q'ty	Qutline	Usage
Owner's manual	1	_____	_____
Installation manual	1	(This manual)	_____
Hook	2		For wall mounting installation
Hanging arm	2		For ceiling installation

**Remote controller & Its Frame**

1. Remote controller.....1

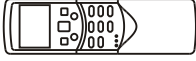

2. Frame.....1



3. Mounting screw  
(ST2.9x10-C-H).....2

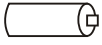
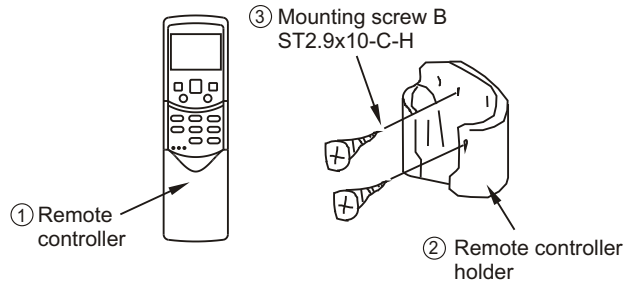

4. Alkaline dry batteries(AM4)  
.....2

### Cautions on remote controller installation

- Never throw or beat the controller.
  - Before installation, operate the remote controller to determine its location in a reception range.
  - Keep the remote controller at least 1m apart from the nearest TV set or stereo equipment. (It is necessary to prevent image disturbances or noise interferences.)
  - Do not install the remote controller in a place exposed to direct sunlight or close to a heating source, such as a stove.
- Note that the positive and negative poles are in right positions when loading batteries.

# INDOOR UNIT INSTALLATION

Installing 10 hanging screw bolts. (4 bolts)

- Please refer to the following figure for the distance measurement between the screw bolts.
  - Please install with 10 hanging screw bolts.
  - The handling to the ceiling varies from the constructions, consult the construction personnel for the specific procedures.
1. The size of the ceiling to be handled ... do keep the ceiling flat. Consolidate the roof beam for possible vibration.
  2. Cut off the roof beam.
  3. Strengthen the place cut off, and consolidate the roof beam.
- Carry out the pipe and line operation in the ceiling after finishing the installation of the main body. While choosing where to start the operation, determine the direction of the pipes to be drawn out. Especially in case there is a ceiling, position the refrigerant pipes, drain pipes, indoor & outdoor lines to the connection places before hanging up the machine.
  - The installation of hanging screw bolts.

## Wooden construction

Put the square timber transversely over the roof beam, then install the hanging screw bolts. (Refer to Chart 1)

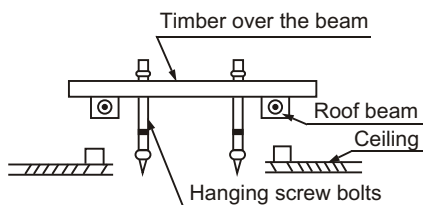

Chart 1

## New concrete bricks

Inlaying or embedding the screw bolts. (Refer to Chart 2)



Chart 2

## For Original concrete bricks

Use embedding screw bolt, crock and stick harness. (Refer to Chart 3)

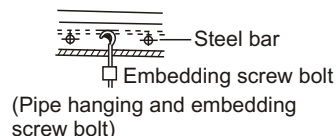

Chart 3

## Steel roof beam structure

Install and use directly the supporting angle steel. (Refer to chart 4)

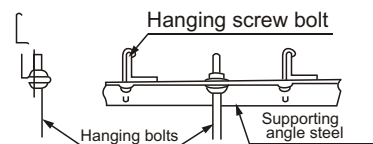

Chart 4

# Wall Mounting Installtion

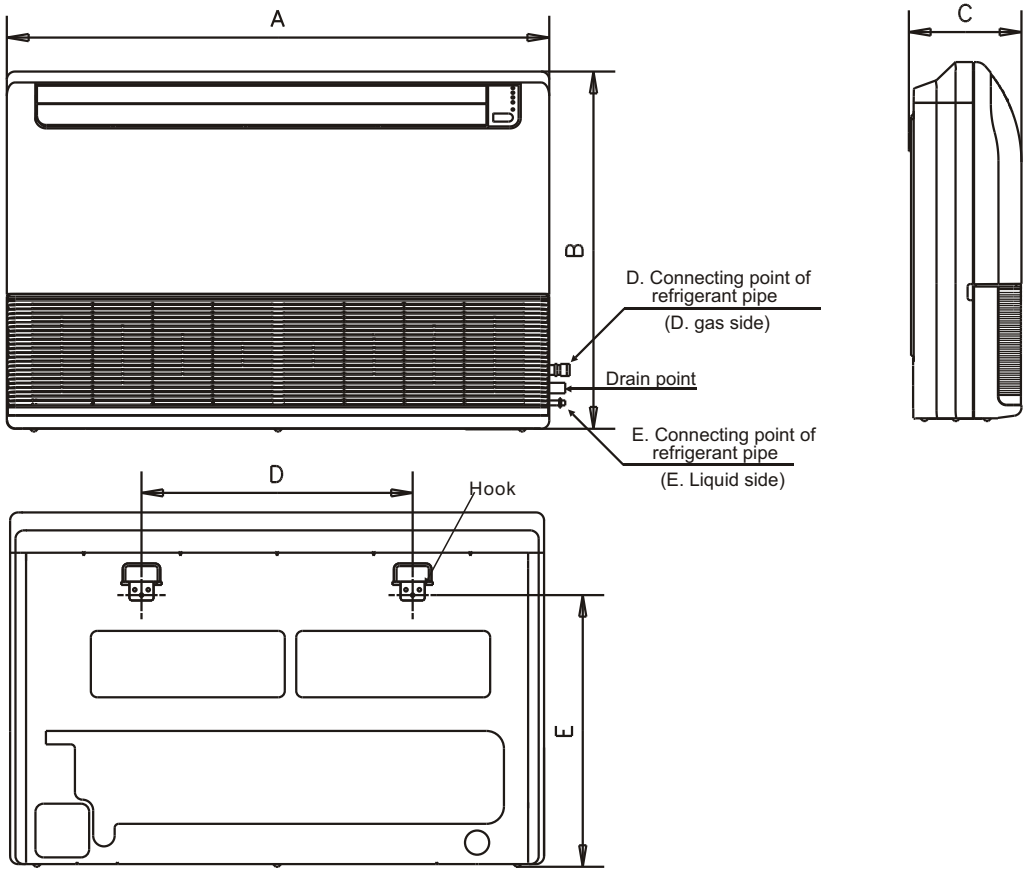

Chart 5

1. Fix the hook with tapping screw onto the wall. (Refer to Chart 6)

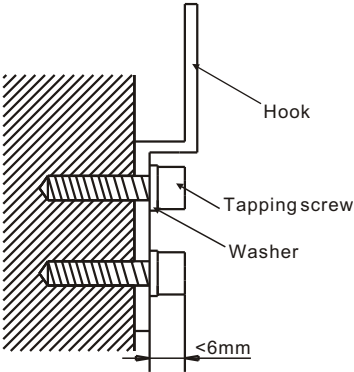

Chart 6

2. Hang the indoor unit on the hook.

## Ceiling Installation

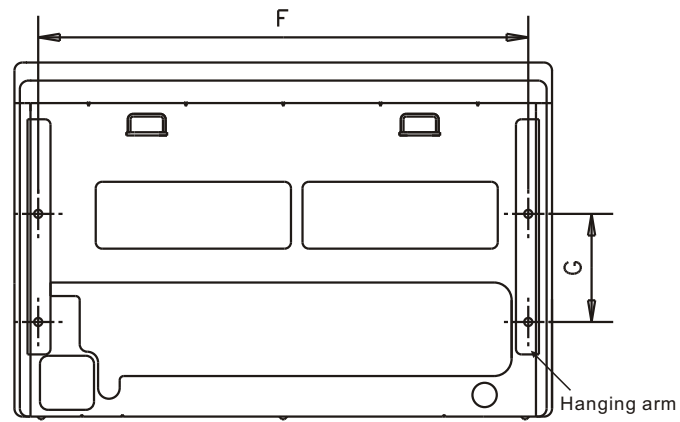

Chart 7

1. Remove the side board and the grille. (Refer to Chart 8)  
(For models 48000 and 60000 Btu/h, do not remove the grille.)

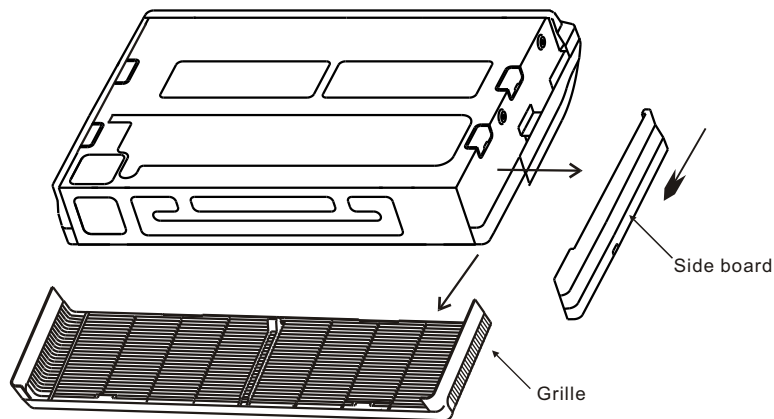

Chart 8

2. Locate the hanging arm on the hanging screw bolt. (Refer to Chart 9)  
Prepare the mounting bolts on the unit. (Refer to Chart 10)

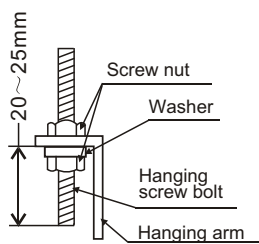

Chart 9

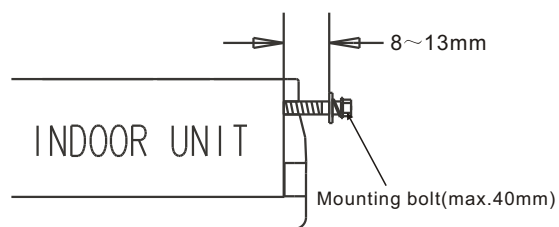

Chart 10

3. Hang the unit on the hanging arm by sliding backward. Securely tighten the mounting bolts on both sides. (Refer to Chart 9)

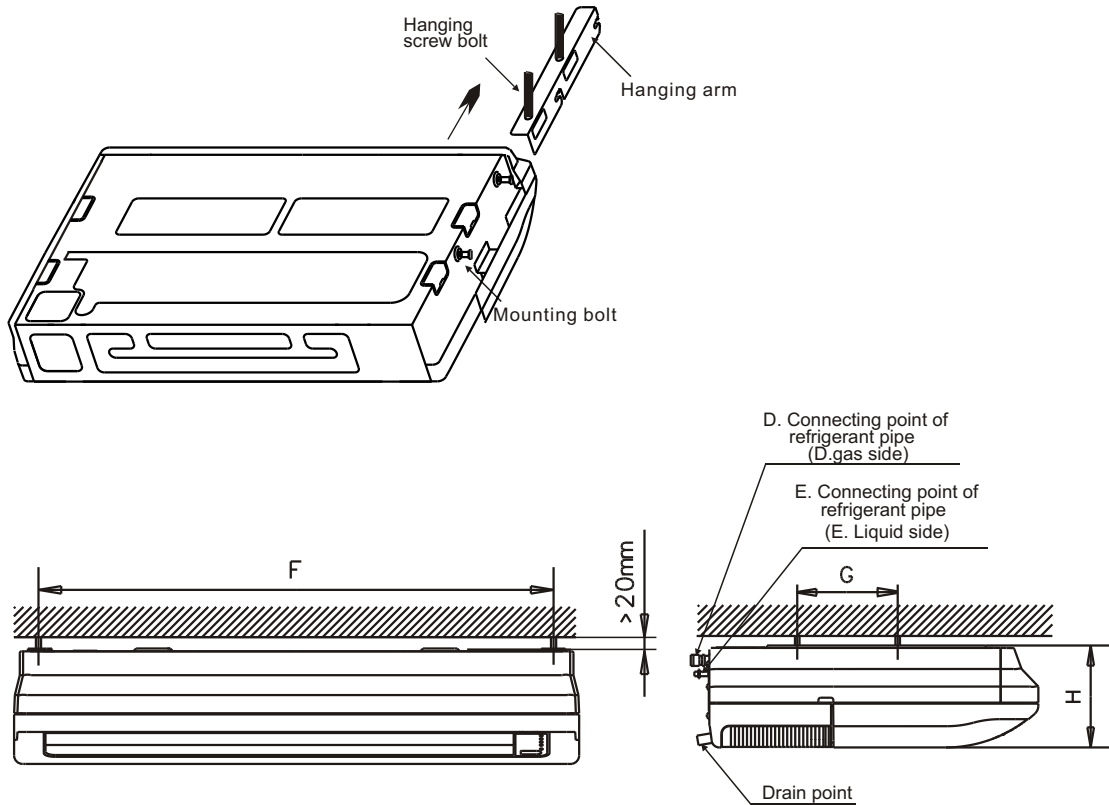

Chart 11

**▲ ATTENTION:** The figures above are based on model with 18000Btu/h as rated capacity, which may differ from the unit you purchased.

**The dimension of the unit**

Capacity (Btu/h)	A	B	C	D	E	F	G	H
5000-7100W	990	660	206	505	506	907	200	203
10000W	1280	660	206	795	506	1195	200	203
14000-18000W	1670	680	244	1070	450	1542	200	240

## OUTDOOR UNIT INSTALLATION

### ⚠ Caution

- Keep this unit away from direct radiation of the sun or other heaters. If unavoidable, please cover it with a shelter.
- In places near coast or with a high attitude where the wind is strong, please install the outdoor unit against the wall to ensure normal performance.
- Use a baffle when necessary.
- In the case of extremely strong wind, please prevent the air from flowing backwards into the outdoor unit. (Refer to chart 12)
- Locate the outdoor unit as close to the indoor unit as possible.
- The minimum distance between the outdoor unit and obstacles described in the installation chart does not mean that the same is applicable to the situation of an airtight. Leave open two of three directions A, B, C.

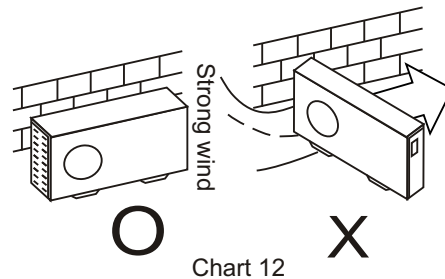

### Necessary Room For Installation And Maintenance (Refer to Chart 13)

If possible, please remove the obstacles nearby to prevent the performance from being impeded by too little of air circulation. Leave open two of the three directions(A,B,C).

### Moving And Installing

- Since the gravity center of this unit is not at its physical center, so please be careful when lifting it with a sling.
- Never hold the air-in of the outdoor unit to prevent it from deforming.
- Do not touch the fan with hands or other objects.
- Do not lean it more than  $45^{\circ}$ , and do not lay it sidelong.

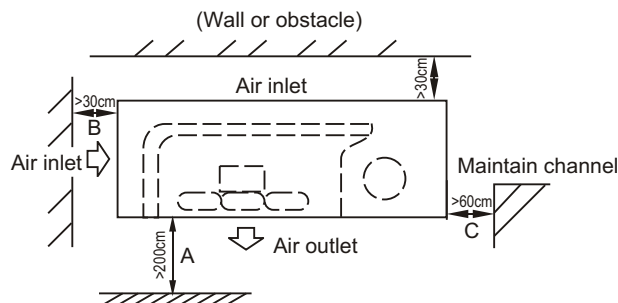

- Please fasten the feet of this unit with bolts firmly to prevent it from collapsing in case of earthquake or strong wind.
- Make concrete foundation. (Refer to chart 14)

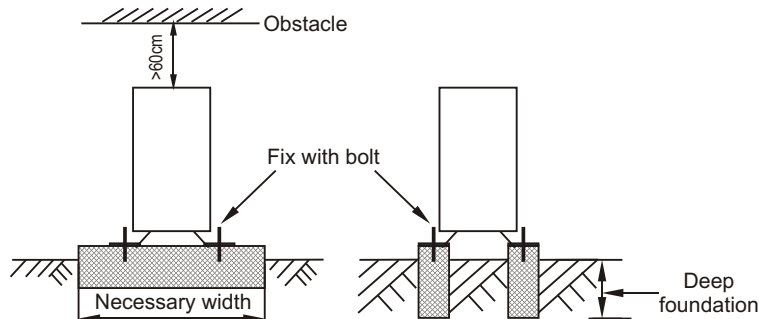

Chart 14

## INSTALL THE CONNECTING PIPE

Check whether the height drop between the indoor unit and outdoor unit, the length of refrigerant pipe, and the number of the bends meet the following requirements:

The max height drop.....10m  
 (If the height drop is more than 10m, you had better put the outdoor unit over above the indoor unit.)  
 The length of refrigerant pipe.....less than 30m  
 The number of bends.....Less than 10

- Do not let air, dust, or other impurities fall in the pipe system during the time of installation.
- The connecting pipe should not be installed until the indoor and outdoor units have been fixed already.
- Keep the connecting pipe dry, and do not let moisture in during installation.

### The Procedure of Connecting Pipes

1. Measure the necessary length of the connecting pipe, and make it by the following way.

1) Connect the indoor unit at first, then the outdoor unit.

- Bend the tubing in proper way. Don't harm them.

## ▲ Cautions

- Daub the surfaces of the flare pipe and the joint nuts with frozen oil, and wrench it for 3~4 rounds with hands before fasten the flare nuts. (Refer to chart 14)
  - Be sure to use two wrenches simultaneously when you connect or disconnect the pipes.
- 2) The stop valve of the outdoor unit should be closed absolutely (as original state). Every time you connect it, first loosen the nuts at the part of stop valve, then connect the flare pipe immediately (in 5 minutes). If the nuts have been loosened for a long time, dusts and other impurities may enter the pipe system and may cause malfunction later. So please expel the air out of the pipe with refrigerant before connection.
  - 3) Expel the air (refer to the “Expel The Air” ) after connecting the refrigerant pipe with the indoor unit and the outdoor unit.  
Then fasten the nuts at the repair-points.

### ■ Notices For Bendable pipe.

- The bending angle should not exceed 90°
- Bending position is preferably in the bendable pipe. The larger the better it is .
- Do not bend the pipe more than three times.

### ■ Bend the connecting pipe of small wall thickness.

- Cut out a desired concave at the bending part of the insulating pipe.
- Then expose the pipe(cover it with tapes after bending).
- To prevent collapsing of deforming, please bend the pipe at its biggest radius.
- Use bender to get a small radius pipes.

### ■ Use the market brass pipe.

Be sure to use the same insulating materials when you buy the brass pipe. (More than 9mm thick)

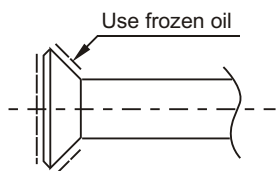

Chart 15

Bend the pipe with thumb



Min-radius 100mm

Chart 16

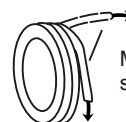

Chart 17

## 2. Locate The Pipe

- 1) Drill a hole in the wall (suitable just for the size of the wall conduit, 90mm in general), then set on the fittings such as the wall conduit and its cover.
- 2) Bind the connecting pipe and the cables together tightly with binding tapes. Do not let air in, which will cause water leakage by condensation.
- 3) Pass the bound connecting pipe through the wall conduit from outside. Be careful of the pipe allocation to do no damage to the tubing.
3. Connect the pipes.
4. Then, open the stem of stop valves of the outdoor unit to make the refrigerant pipe connecting the indoor unit with the outdoor unit fluently flow.
5. Be sure of no leakage by checking it with leak detector or soap water.
6. Cover the joint of the connecting pipe to the indoor unit with the soundproof/insulating sheath (fittings), and bind it well with the tapes to prevent leakage.

## CONNECT THE DRAIN PIPE

### 1. Install indoor unit drain pipe

The outlet has **PTI screw bread**, Please use sealing materials and pipe sheath (fitting) when connecting PVC pipes.

### CAUTIONS

- The drain pipe of indoor unit must be heat insulated, or it will condense dew, as well as the connections of the indoor unit.
- Hard PVC binder must be used for pipe connection, and make sure there is no leakage.
- With the connection part to the indoor unit, please be noted not to impose pressure on the side of indoor unit pipes.
- When the declivity of the drain pipe downwards is over 1/100, there should not be any winding.
- The total length of the drain pipe when pulled out transversely shall not exceed 20m, when the pipe is over long, a prop stand must be installed to prevent winding.
- Refer to the figures on the right for the installation of the pipes.

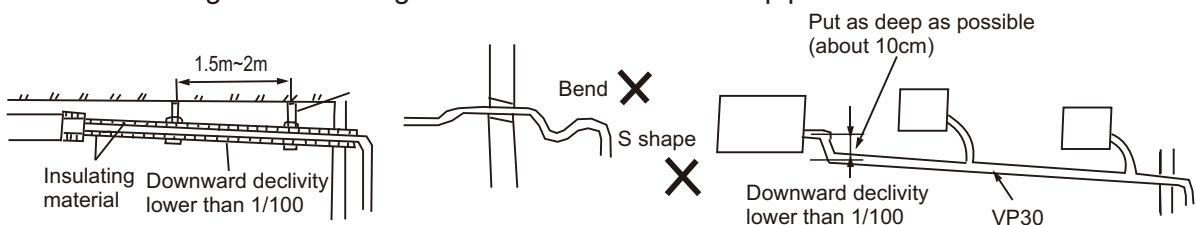

### 2. Drainage test

- Check whether the drain pipe is unhindered
- New built house should have this test done before paving the ceiling.

### 3. Drain Elbow Installation

Fit the seal into the drain elbow, then insert the drain elbow into the base pan hole of outdoor unit, rotate 90° to securely assemble them. Connect the drain elbow with an extension drain hose (Locally purchased), in case of the condensate draining off the outdoor unit during the heating mode. (Refer to Chart 17)

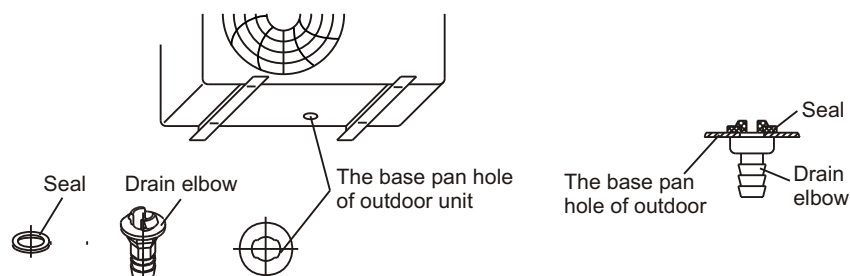

Chart 17



TYPE(for R22)		12000~18000Btu/h (Cooling Only)	24000-36000Btu/h (Cooling Only)	36000-60000Btu/h (Cooling Only)
POWER	PHASE	1-PHASE	1-PHASE	3-PHASE
	FREQUENCY AND VOLT	220-240V~, 50Hz	220-240V~, 50Hz	380V 3N~, 50Hz
CIRCUIT BREAKER/FUSE (A)		20/16	40/25	40/20
INDOOR UNIT POWER WIRING(mm <sup>2</sup> )		3x2.5	3x2.5	5x2.5
INDOOR/OUTDOOR CONNECTING WIRING  (mm <sup>2</sup> )	GROUND WIRING	2.0	2.5	2.5
	OUTDOOR UNIT POWER WIRING	——	3x2.5	5x2.5
	STRONG ELECTRIC SIGNAL	3x2.0	1x2.0	1x2.0
	WEAK ELECTRIC SIGNAL	——	1-core sheild wire 1x0.5mm <sup>2</sup>	——

TYPE(For R22)		24000 Btu/h (Cooling Only)	36000 Btu/h (Cooling Only)	48000 Btu/h (Cooling Only)
POWER	PHASE	1-PHASE	1-PHASE	1-PHASE
	FREQUENCY AND VOLT	220V~, 60Hz	220V~, 60Hz	220V~, 60Hz
CIRCUIT BREAKER/FUSE (A)		28/12	42/17	42/22
INDOOR UNIT POWER WIRING(mm <sup>2</sup> )		3x2.5	3x2.5	3x4.0
INDOOR/OUTDOOR CONNECTING WIRING  (mm <sup>2</sup> )	GROUND WIRING	2.0	2.5	2.5
	OUTDOOR UNIT POWER WIRING	3x2.5	3x2.5	3x4.0
	STRONG ELECTRIC SIGNAL	2X2.0	2X2.0	2X2.0
	WEAK ELECTRIC SIGNAL	——	——	——

## ■ Wiring Chart

Chat 18

Installing wiring chart, refer to link circuit chart for details.

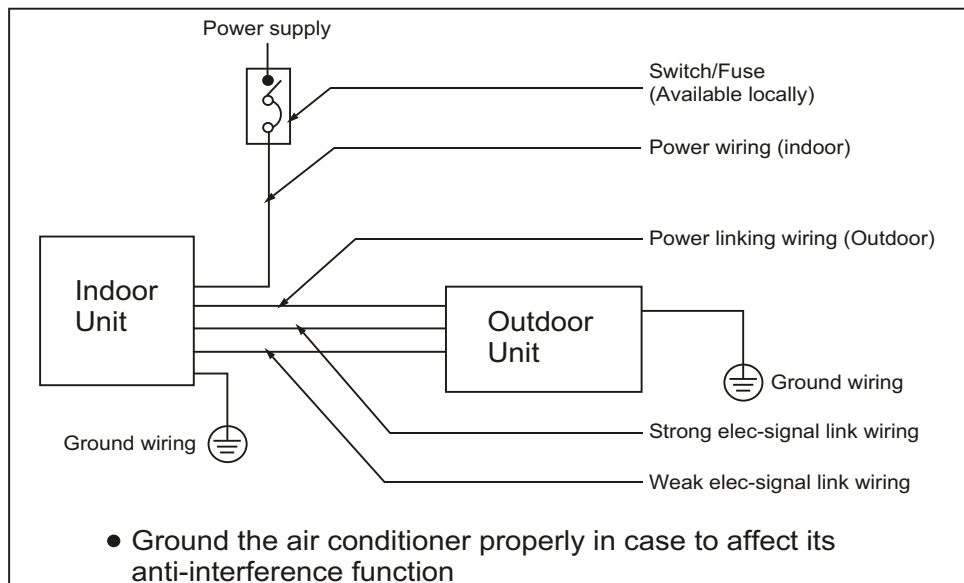
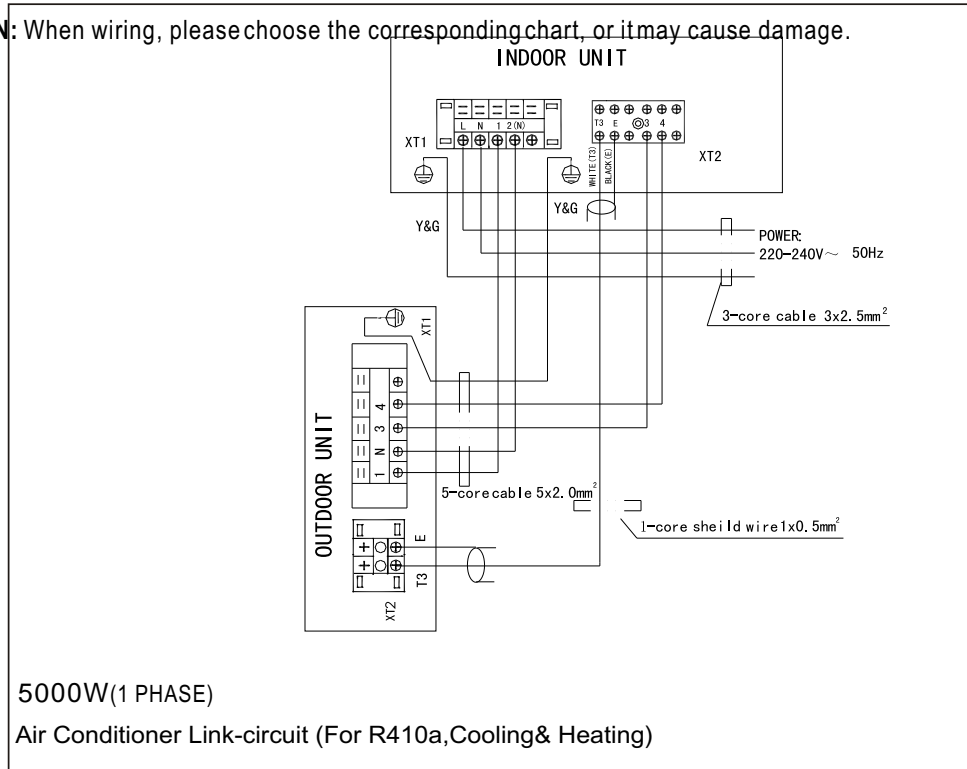

Chart 19



**CAUTION:** When wiring, please choose the corresponding chart, or it may cause damage.



Chat 20

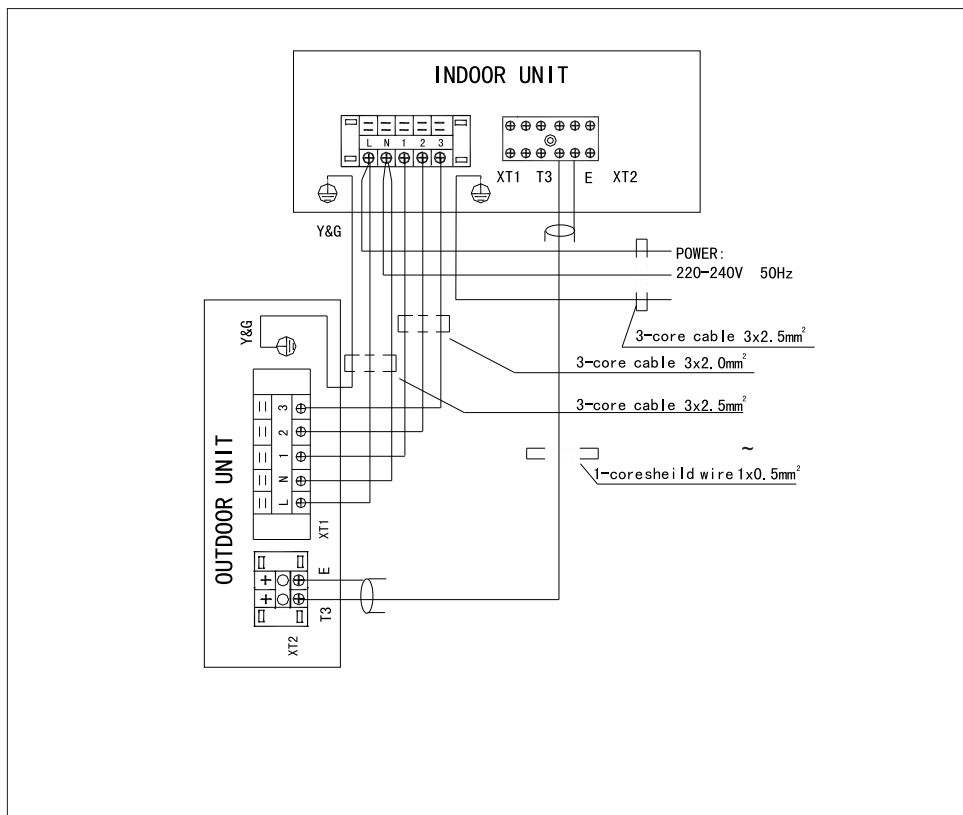

Chat 21

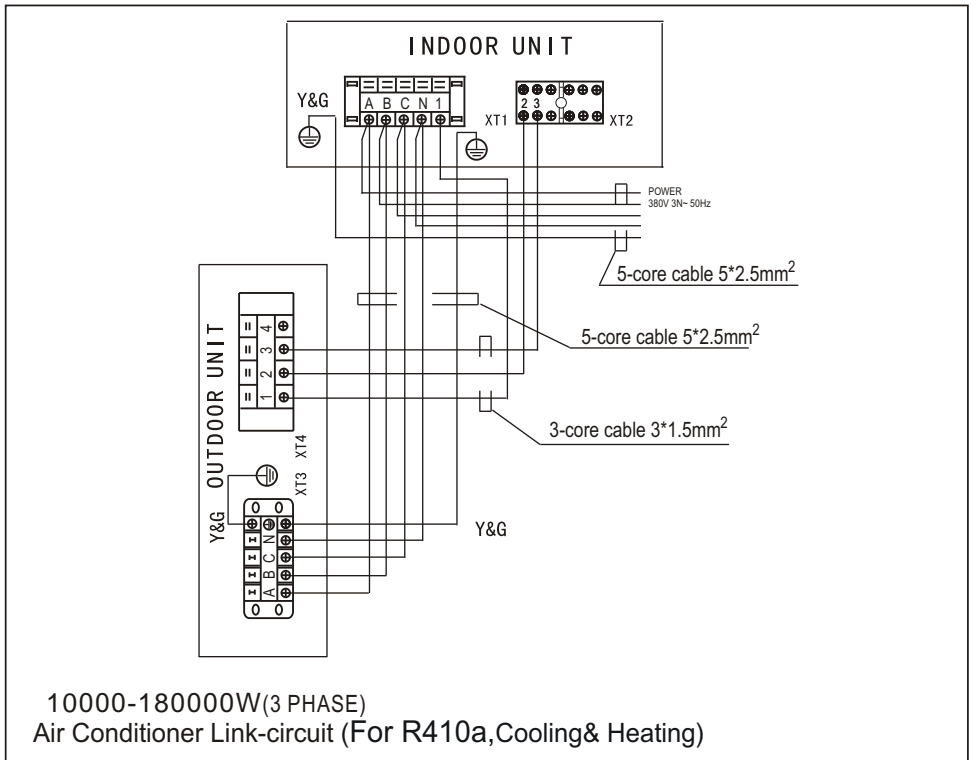

Chat 22

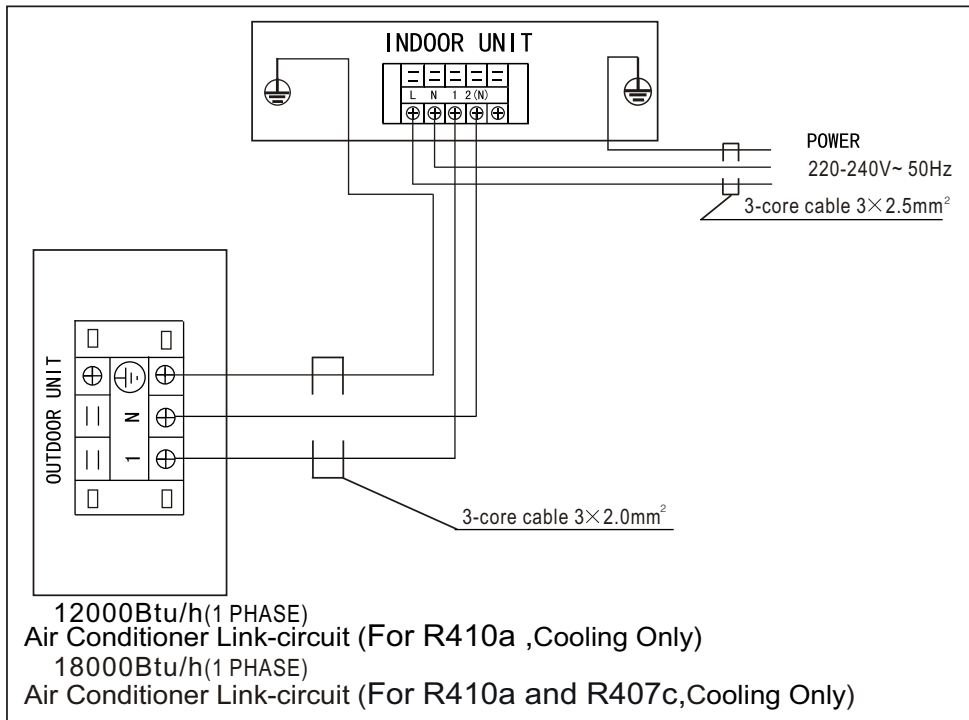

Chat 23

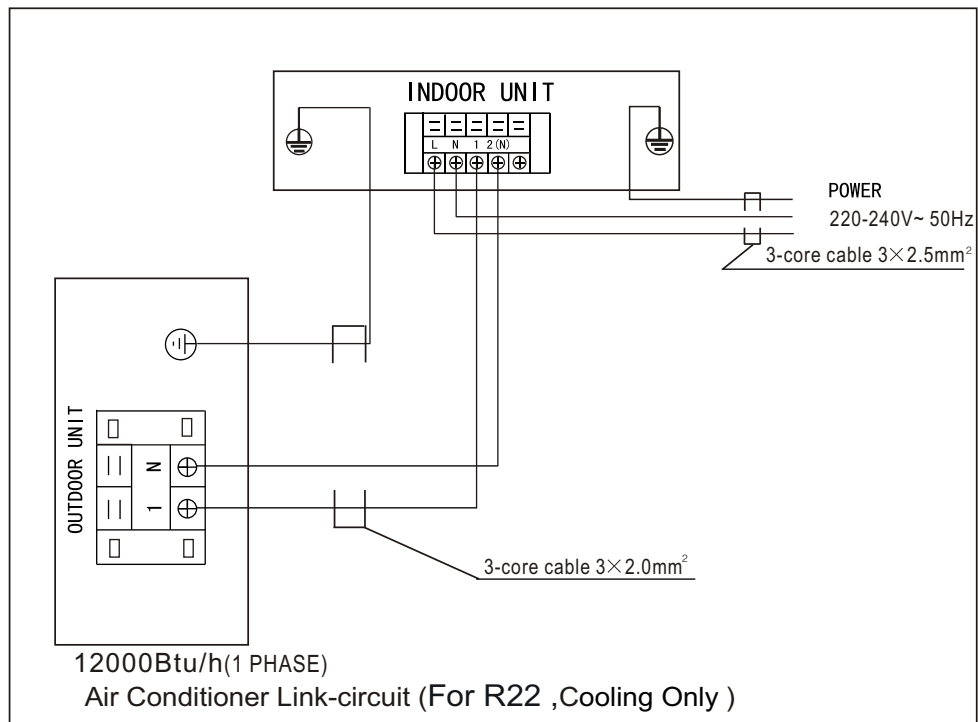

Chart 34

## The Outdoor Units

Disassemble the bolts from the maintenance board, and pull it in the direction of the arrow to remove the protection board.

**Notice:** Do not scratch the surface during operation.

**⚠ ATTENTION:** Chart 35 is based on one type of outdoor units, which may look different from your own outdoor unit.

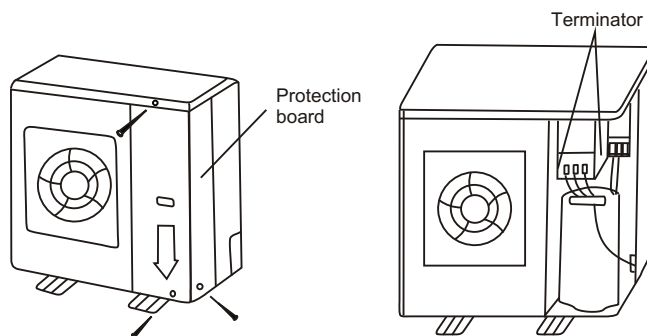

Chart 35

## TEST OPERATION

1. The test operation must be carried out after the entire installation has been completed.
2. Please confirm the following points before the test operation:
  - The indoor unit and outdoor unit are installed properly.
  - Tubing and wiring are correctly completed.
  - The refrigerant pipe system is leakage-checked.
  - The drainage is unimpeded.
  - The heating insulation works well.
  - The ground wiring is connected correctly.
  - The length of the tubing and the added stow capacity of the refrigerant have been recorded.
  - The power voltage fits the rated voltage of the air conditioner.
  - There is no obstacle at the outlet and inlet of the outdoor and indoor and indoor units.
  - The gas-side and liquid-side stop valves are both opened.
  - The air conditioner is pre-heated by turning on the power.
3. According to the user's requirement, install the remote controller frame where the remote controller's signal can reach the indoor unit smoothly.
4. Test operation
  - Set the air conditioner under the mode of "COOLING" with the remote controller, and check the following points per the "Owner's Manual" If there is any malfunction, please resolve it through chapter "Troubles And Causes" in the "Owner's Manual".
    - 1) The indoor unit
      - a. Whether the switch on the remote controller works well.
      - b. Whether the buttons on the remote controller works well.
      - c. Whether the air flow louver moves normally.
      - d. Whether the room temperature is adjusted well.
      - e. Whether the indicator lights normally.
      - f. Whether the temporary buttons works well.
      - g. Whether the drainage is normal.
      - h. Whether there is vibration or abnormal noise during operation.
      - i. Whether the air conditioner heats well in the case of the HEATING/COOLING type.
    - 2) The outdoor unit
      - a. Whether there is vibration or abnormal noise during operation.
      - b. Whether the generated wind, noise, or condensed water by the air conditioner have influenced your neighborhood.
      - c. Whether any of the refrigerant is leaked.

### **Cautions**

A protection device delays the start of compressor for about 3 minutes when it is restarted immediately after switching on the power.

AlpicAir AFI\_2007